



DRAWER BOXES



PRODUCT-SPECIFIC CATALOGS

Call our friendly customer service staff to request any or all of these five catalogs. Refer to the contents page of this catalog (page 7) to see what's in each one. For prices and detailed specifications, refer to our website for a downloadable Price & Specification Document.



DOORS & DRAWER
FRONTS



DRAWER
BOXES



MOULDING,
TURNINGS & MORE
COMING SOON



FINISHES
COMING SOON



CABINET
REFACING
COMING SOON





THE ART OF
CRAFTSMANSHIP





HISTORY OF KEYSTONE

Keystone Wood Specialties president Sam Stoltzfus got into woodworking as a young boy. Having grown up the son of an Amish farmer and carpenter, he liked tinkering with wood and mimicking toys that his great-uncle Levi made. In 1972, at the age of 21, he founded his then one-man shop in Ronks, PA. Sam would make the cabinets, getting his doors from a supplier, and his father, along with his brothers and a friend, would install the kitchens. If you ask Sam about the early years, he will proceed to tell you numerous stories of the good times he shared with his grandfather, also a farmer and carpenter, while making deliveries to customers.

From the beginning, Keystone Wood Specialties has been committed to making the highest quality products. In 1977, Sam purchased machinery to begin making his own doors. Shortly thereafter, he began making doors for a few local cabinetmakers. From there, he saw an opportunity to grow into manufacturing cabinet components and stopped making cabinets altogether. In an interview, Sam mentioned, "That was a big switch, because it was like starting all over again. It was tough going for a couple years, to bring everything to the quality level we wanted." And they did—Keystone's quality continues to rank among the highest in the industry.

In 1984, Sam, along with about a dozen employees, moved into the current building on Old Philadelphia Pike. Keystone continued to grow its product line and was among the first to offer dovetailed drawers and to cater to the refacing industry. Over the years, there have been several additions and improvements to the existing building and workforce. As the next generation learns the trade, Keystone continues to focus on providing the highest quality cabinet components—including finished or unfinished doors and drawer fronts, drawer boxes, face frames, wainscoting, moulding, and more.



WHY CHOOSE KEYSTONE

Whether driven by your own ideas or a customer's unique desires, Keystone Wood Specialties promises to deliver the high-end custom components it takes to help you create beautiful cabinetry and furniture.

At Keystone, you will always be greeted by a live, knowledgeable customer service representative. Whether you just have a question about our products, want help placing an order, or need to discuss a problem with an existing order, our staff is here to ensure that you and your customers are completely satisfied.

We have everything you need to complete your custom project—doors and drawer fronts, dovetailed drawer boxes, face frames, moulding, valances, wainscoting, turnings and corbels, radius doors, plywood and veneer, finishing options, and more. If you don't see what you're looking for, no problem. We pride ourselves on that one-of-a-kind custom order and have on-site machining capabilities to create all of the tooling needed to get the job done in a timely manner.

You can trust Keystone to give you the personal attention you and your customers require. We produce each order from the same lot of wood, ensuring the grains are similar for a perfect outcome. Whether you order one door or one thousand doors, we will treat your order with the same care and attention to detail—all with unmatched quality, all to help you build truly one-of-a-kind cabinetry your customers will love for a lifetime.









CONTENTS

THINGS YOU NEED TO KNOW.....	8
FREQUENTLY ASKED QUESTIONS.....	9
KEYSTONE'S FAMILY OF DRAWER BOXES.....	10-11
OPTIONS AND SIZES.....	12-13
SPECIALTY DRAWER BOXES.....	14-19
CUTLERY TRAYS.....	15
DIVIDER DRAWERS.....	15
WASTE BIN PULL-OUTS.....	16
CORNER SHELVES.....	16
KNIFE BLOCK DRAWERS AND DRAWER INSERTS.....	17
SPICE DRAWERS AND DRAWER INSERTS.....	17
U-DRAWERS.....	18
CORNER DRAWERS.....	18
PEG BOARD DRAWERS.....	18
SOCK & TIE DRAWERS.....	18
PAN PULL-OUTS.....	18
WINE DRAWER INSERTS.....	19
LATTICE WINE RACKS.....	19
WINE BOXES.....	19
STEMWARE RACKS.....	19
CAN/SPICE PULL-OUTS.....	19
LASER ENGRAVING.....	20
DRAWER SLIDES.....	21
ROLLOUT TRAY SYSTEM.....	22-23
DRAWER WOOD SPECIES.....	24-25
INDEX.....	26
CONTACT US.....	27

DOORS & DRAWER FRONTS CATALOG

DOORS AND DRAWER FRONTS
APPLIANCE PANELS
ARCH PANELS
WAINSCOTING
FACE FRAMES

MOULDING & MORE CATALOG

BASEBOARD, CASING, CROWN
MOULDING, AND MORE
MOULDING BUILDUPS AND PERIOD
SUGGESTIONS
TURNED COLUMNS AND BUN FEET
FLUTED AND PLAIN PILASTERS
WHITE RIVER CORBELS AND
ADORNMENTS

FINISHES CATALOG

HAND-WIPED AND SPRAY STAINS
SOLID PAINT COLORS
FULL AND ACCENT GLAZING
DISTRESSING AND SPECIAL
EFFECTS
CUSTOM COLOR MATCHING

CABINET REFACING CATALOG

DOORS, DRAWERS, FACE FRAMES,
AND MOULDING
VENEER AND PLYWOOD
RTA RANGE HOODS
REFACING METHODS, TOOLS, AND
TECHNIQUES
HANDS-ON TRAINING
REFACING SALES KIT

THINGS YOU NEED TO KNOW

SETTING UP AN ACCOUNT WITH US

Our customer service professionals will be happy to set up an account with you. They will gather all the needed information and assign you a customer number for use in all correspondence, including quotes and orders.

PLACING ORDERS WITH US

We allow several ways for you to place an order.

Online keystonewood.com

E-mail info@keystonewood.com

Fax Local: 717.299.9654
Toll-Free: 800.253.0805

US Mail Keystone Wood Specialties Inc.
PO Box 10127
Lancaster, PA 17605-0127

Verbal Although we do not recommend verbal orders, we may accept them for simple orders. Most orders, especially with special instructions or custom features, cannot be accepted verbally and must be in writing.

Notes

- Keystone has preprinted order forms for your convenience for faxing, e-mailing, or mailing.
- Incomplete order forms may delay the quoting process and your order delivery time.
- Please do not submit an order more than once. Submitting the same order multiple times or by different methods may result in duplicated orders. Keystone cannot be responsible for duplicated orders.

TRADE DISCOUNTS

Orders over \$200 of discountable items are subject to a trade discount if paid within 60 days. Certain items are not subject to trade discounts. Contact customer service for complete information.

SHIPPING, DELIVERY, AND PICKUP

We ship anywhere in the country, deliver locally, or welcome our customers to pick up their orders at our facility. While you are here, ask for a plant tour. We would be happy to show you what we do.

REMAKES AND ADD-ONS

When remakes and add-ons are needed, our goal is to do all we can to ensure your customer's needs are met as quickly as possible.

TYPOGRAPHICAL ERRORS

We try very hard to avoid typographical errors, but sometimes they do occur. Keystone accepts no financial responsibility for inadvertent errors in this or any of our printed materials.

FREQUENTLY ASKED QUESTIONS

DO YOU SELL TO RETAIL CUSTOMERS?

No. We are strictly a wholesale, business-to-business manufacturer of wood products for the custom cabinet, furniture, and remodeling industry.

DO YOU MAKE PRODUCTS IN ANY AVAILABLE WOOD SPECIES?

Yes. See page 25 for a list of our wood species. Other species may be available upon request.

DO YOU PROVIDE FINISHING FOR YOUR PRODUCTS?

Yes. See our Finishes Catalog or website for complete information.

WHAT ARE YOUR ESTIMATED LEAD TIMES?

Estimated lead times can vary according to many factors, including size and complexity of your order. Our typical lead time is within a few weeks for most products. For detailed information on our current lead times, please call customer service.

HOW WILL I KNOW MY ORDER HAS SHIPPED?

Keystone will e-mail tracking information to you at time of shipment.

DO YOU REQUIRE A MINIMUM QUANTITY TO PLACE AN ORDER?

No. A single drawer or a thousand drawers, all orders receive the same personal attention.

CAN I GET A "BALLPARK" ESTIMATE?

No. There are too many variables to give you useful information without an actual quote, which you can usually have within 24 hours. You can also figure your own cost by using the information in our downloadable Price & Specification Document.

CAN I SEND A DRAWING OR A PHOTO OF A CUSTOM DRAWER I WANT?

Yes. We specialize in one-of-a-kind custom orders.

CAN I SEND A BLUEPRINT OR PLANS FOR A JOB AND HAVE YOU PULL THE DIMENSIONS FOR WHAT I NEED?

We do not do takeoffs from blueprints or plans. You need to send us a list of items. Order forms are available online for your convenience.

CAN ANY CUSTOMER SERVICE REPRESENTATIVE HANDLE MY ACCOUNT?

Yes. All of our friendly customer service professionals are knowledgeable, capable, and ready to assist you.

HOW CAN I GET A QUOTE?

Same method as placing an order, except request a quote.



KEYSTONE'S FAMILY OF DRAWER BOXES



DOVETAILED DRAWER BOXES

- Available in most wood species
- Selected for color
- Any height
- One-piece solid wood sides (up to 8")
- Plywood bottoms
- Dovetails are puttied
- Top edges are chamfered
- Finished or unfinished
- Options and sizes (pages 12–13)
- Specialty boxes (pages 14–19)



ALTERNATIVE OPTIONS FOR QUANTITY AND COST

- High quantities only
- Lower cost dovetailed box
- Available only in soft maple
- Not selected for color
- Finished or unfinished
- Options and sizes (pages 12–13)
- Call customer service for more details



DOWELED DRAWER BOXES

- Lower cost drawer box
- Available in maple plywood and white or gray melamine
- Edgebanded
- Prefinished
- Ships unassembled
- Heights: 2³/₄", 3", 4", 4³/₄", 6", 7", 8", 9³/₄", 12"
- Minimum size: 4" wide x 6" deep
- 1/2" sides and 1/4" bottoms

DRAWER SLIDES

Keystone carries a selection of undermount and side-mount drawer slides. Order them with your boxes. See page 21.

OPTIONS & SIZES

ASSEMBLY PREFERENCES

- Unassembled without bottoms
- Unassembled with bottoms
- Assembled and sanded, ready to finish
- Assembled and prefinished*

*Standard finish for drawer boxes is two coats of catalyzed varnish.

WOOD SPECIES*

- Alder
- Aromatic cedar
- Ash
- Cherry
- Mahogany
- Maple, hard
- Maple, soft
- Paulownia
- Pine, clear
- Pine, knotty
- Poplar
- Red oak
- Walnut
- White oak, quartersawn

*For additional wood species not listed above, call customer service for availability.

THICKNESS OPTIONS

- Front, back, and sides: 1/2", 5/8", or 3/4"* thick
- Plywood bottoms: 1/4" (most species), 3/8" (maple only), or 1/2" (maple only)**

*For 3/4" thick boxes, undermount slides are available in case lots only.

**Other species may be available upon request.

MINIMUM SIZES

- Height: 2" (increases in 1/2" increments)
- Width: 4" (increases in 1/16" increments)
- Depth: 6" (increases in 1/16" increments)

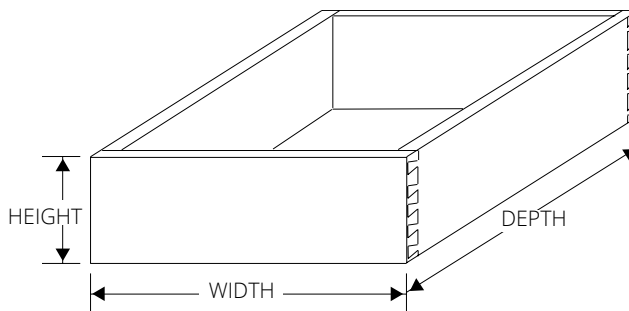

Height measured in 1/2" increments only.

DRAWER BOX SIDES

- Chamfered edges unless otherwise specified
- Square top edges available upon request*

*Square top edges will render the box approximately 1/8" undersized in height.

**Standard bottom groove placement is 1/2" from the bottom. Custom placement is available.

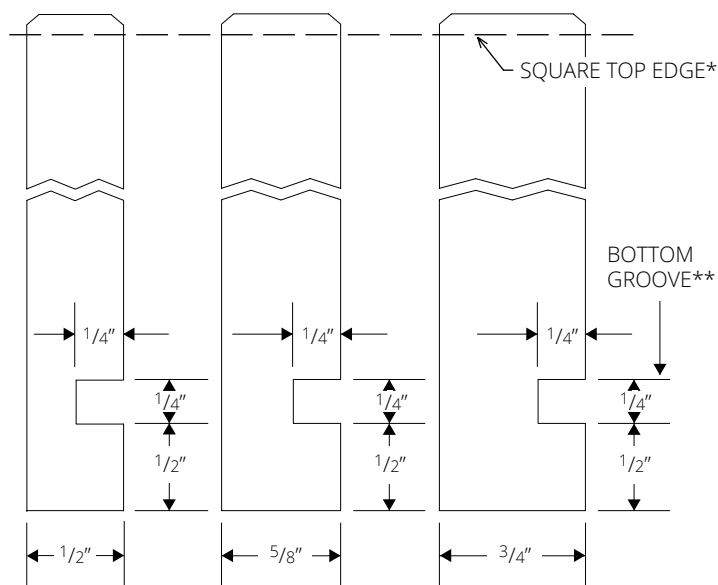

OPTIONS

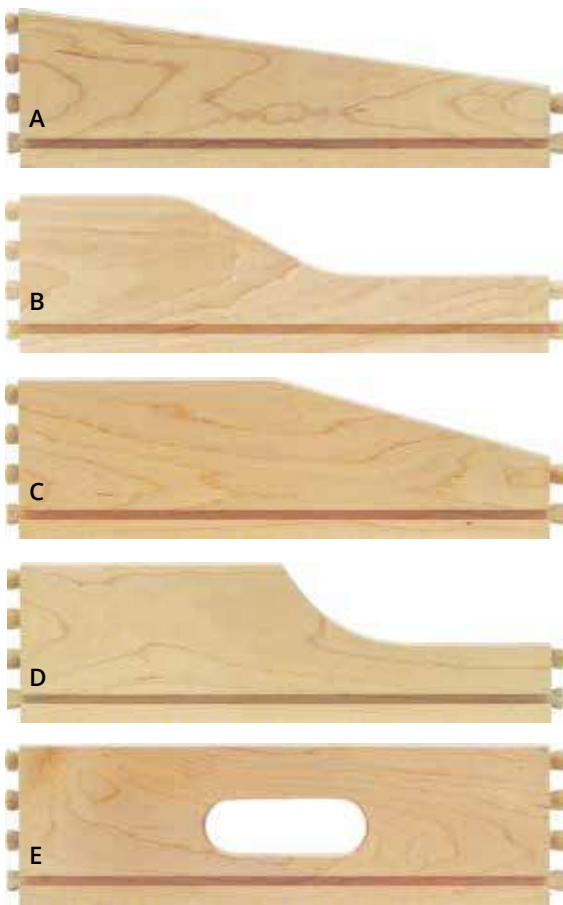

PULL-OUT TRAY OPTIONS

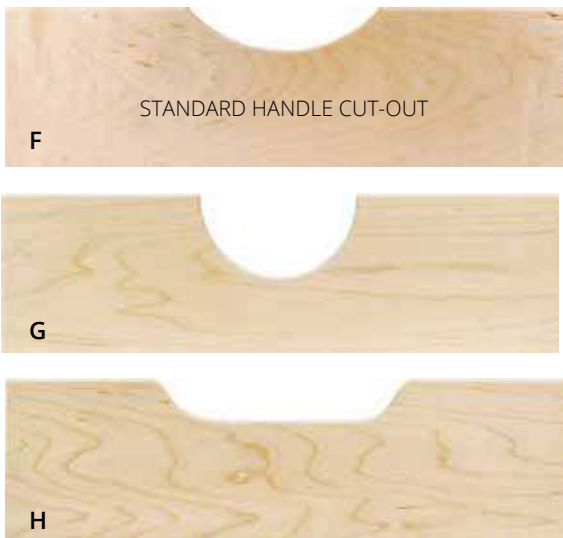

NOTCHING FOR UNDERMOUNT DRAWER SLIDES

Drawers can be notched for all makes of undermount slides. The standard notch width is 2" for most slides, including Blum BLUMOTION soft-close drawer slides. Custom notching is available.

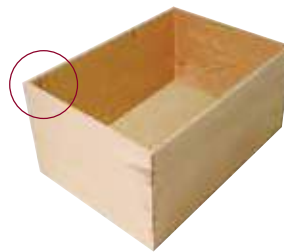

SLOTS FOR FILE HANGERS

Slots can be routed in fronts or sides for hanging file bars. Slots are 1/8" wide.



GROOVE FOR SLIDING TOPS

Grooves and sliding lids for bread drawers are available.



EARS FOR PULL-OUT TRAYS

Drawers as pull-out trays are available with "ears" that extend past the drawer.

Please specify the amount of ear extension.



HANDLE CUT-OUTS

Handles for pull-out trays are available as shown. Custom handles can be routed.



DON'T SEE WHAT YOU WANT? SEND US YOUR DRAWING.

SPECIALTY DRAWER BOXES

Choose from one of our specialty drawer boxes, or create one of your own.

Keystone specializes in building custom drawer boxes, including custom cut-outs, side shapes, dividers, sizes, and more.

If you don't see exactly what you want, send us your drawing.



SPECIALTY DRAWER BOXES



CUTLERY TRAYS

Order Cutlery Trays from six standard configurations, depending on your drawer width, or from your own custom design. Each is crafted to fit properly in our dovetailed drawer boxes and are available finished or unfinished and in a wood species to match your drawer box order. See page 25 for available wood species.

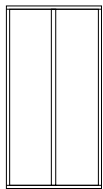

TRAY 1
7¹/₄"-10¹/₂"

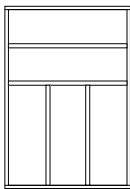

TRAY 2
10⁵/₈"-13⁷/₈"

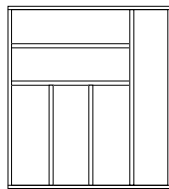

TRAY 3
14"-18"

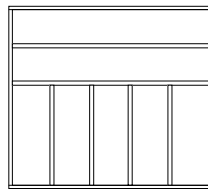

TRAY 4
18¹/₈"-20¹/₂"

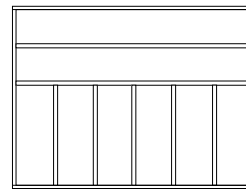

TRAY 5
22⁵/₈"-26³/₄"

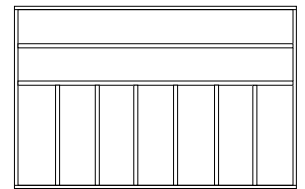

TRAY 6
26⁷/₈"-31¹/₈"



DOUBLE CUTLERY TRAY BOXES

Double Cutlery Trays are available for boxes as small as 4" high, fitting in a typical top drawer configuration. The 4" box uses two 1¹/₂" high trays.

Other Double Cutlery Tray boxes incorporate two 2¹/₄" high trays in a 5¹/₂" or 6" high box. All Double Cutlery Tray assemblies use full-extension slides.

Variation: order the bottom layer with a knife block insert (see page 17).



FIXED/REMOVABLE DIVIDER DRAWERS

Drawers may be ordered with fixed (permanent) or removable (non-adjustable) dividers similar to cutlery tray inserts. Order them in any custom configuration.

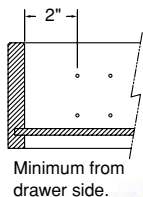

Minimum from drawer side.

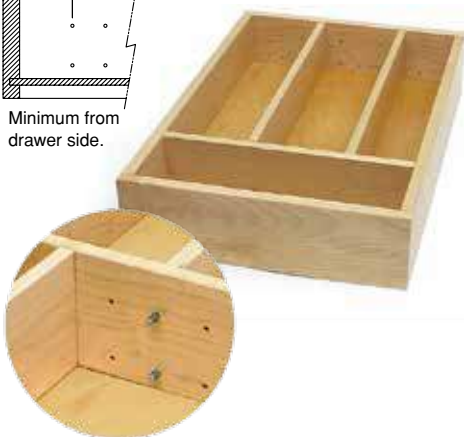

ADJUSTABLE DIVIDER DRAWERS

- Dividers adjust side to side (Horizontal dividers are not adjustable in standard configurations. However, custom design requests are always welcome.)
- Specify the number of dividers you want
- Three standard configurations
- Available finished or unfinished
- Available in all wood species

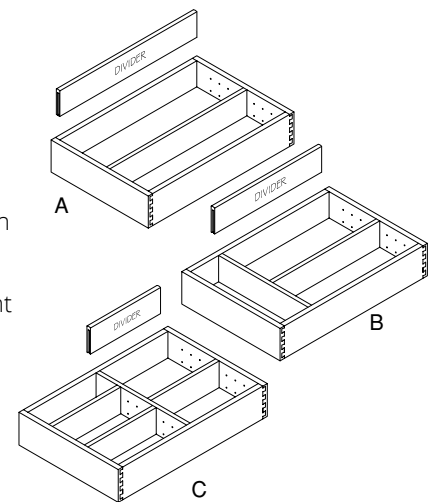

SPECIALTY DRAWER BOXES



BOTTOM MOUNTED
(includes a drawer bottom,
single bin shown)



TOP MOUNTED
(no drawer bottom included,
double bin shown)



**TOP MOUNTED,
WITH COVERED SIDES**
(no drawer bottom included,
single bin shown)



**TOP MOUNTED,
WITH ANGLED SIDES**
(no drawer bottom included,
single bin shown)

WASTE BIN PULL-OUTS

Top or bottom mount, 1 or 2 small or large bins, or a combination of 1 small and 1 large bin. Box tops are 1/2" thick with a 1/4" overhang on the sides, flush on the front and back. Pull-Outs may be ordered finished or unfinished, in any available species.

MINIMUM TOP SIZES, TOP OR BOTTOM MOUNT, INCLUDING THE 1/4" OVERHANG ON EACH SIDE (1/2" OVERALL):

BOX THICKNESS	1 LARGE BIN	2 LARGE BINS	1 SMALL BIN	2 SMALL BINS	1 LARGE BIN & 1 SMALL BIN
1/2"	11 3/4" x 15 1/2"	16" x 23"	11 1/4" x 15"	15 1/2" x 22"	16" x 22 1/2"
5/8"	12" x 15 3/4"	16 1/4" x 23 1/4"	11 1/2" x 15 1/4"	15 3/4" x 22 1/4"	16 1/4" x 22 3/4"
3/4"	12 1/4" x 16"	16 1/2" x 23 1/2"	11 3/4" x 15 1/2"	16" x 22 1/2"	16 1/2" x 23"

TRASH BIN SIZES: Large Bin—15 1/4" x 11 1/4" x 20" high; Small Bin—14 1/2" x 10 1/2" x 15" high. Bins and side-mount drawer slides are sold separately.

CORNER SHELVES

Corner shelves are made with 3/4" edgebanded plywood sides and 3/4" solid wood shelves. Order them to the size you want, and include the number of shelves. As always, if you don't see what you want, send us your drawing.



SPECIALTY DRAWER BOXES



KNIFE BLOCK DRAWERS AND DRAWER INSERTS

Knife Block Drawers and Knife Block Inserts, available to the customer's specifications. Order the box with the insert, or the insert alone. Minimum drawer height is 3¹/₂".

Minimum knife block depth is 16³/₄". Order them prefinished or unfinished, and in most wood species.

Cutlery not included.



SPICE DRAWERS AND DRAWER INSERTS

Spice Drawers feature stepped inserts designed for maximum fit and visibility of spice products. The inserts may be glued permanently in place, or shipped loose for additional flexibility. Order the box with the inserts or the inserts by themselves.

The minimum drawer height is 4". The standard drawer depth is 21".

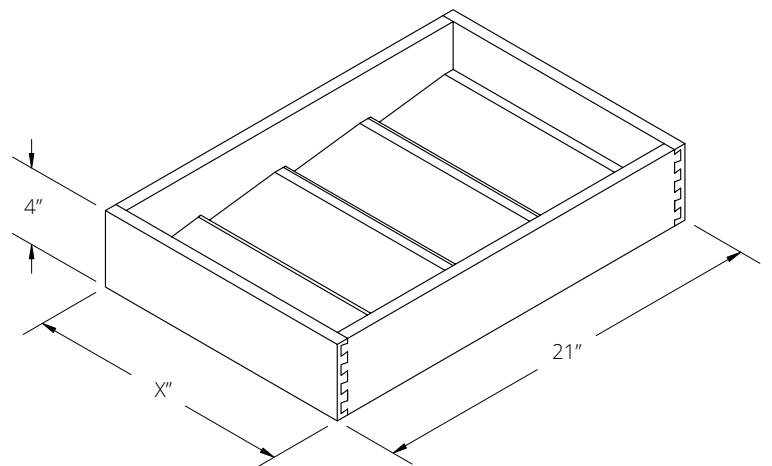
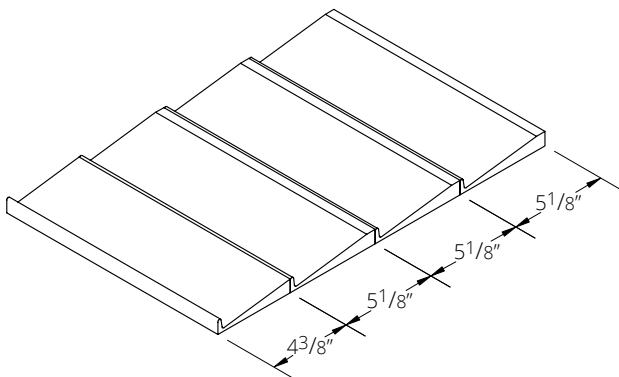

SPECIALTY DRAWER BOXES



U-DRAWERS

Designed to custom fit around under-sink plumbing, U-Drawers are made to customer specifications, in your choice of wood species, finished or unfinished. See our roll-out tray products on pages 22 and 23.



CORNER DRAWERS

Order 90° Corner Dovetailed Drawer Boxes in any configuration you need. Drawers can be completely open (as shown), made with permanent dividers, or fitted with tray inserts.

Available with optional Blum undermount drawer slides, Corner Drawer Boxes can be ordered in 1/2", 5/8", or 3/4" thicknesses and in any height as small as 3". Each is crafted to your specifications and is available finished or unfinished, and in most wood species.



PEG BOARD DRAWERS

Peg Board Drawers have a peg board bottom made from 1/2" plywood to accept included pegs. Pegs help to keep items organized and stable, whether it be stacks of small dishes or large pots. Four pegs are included standard. Additional pegs are available upon request.



SOCK & TIE DRAWERS

Sock & Tie Drawers are built with half-lapped, removable dividers. Equally sized compartments may vary according to box size and are no smaller than 3 1/2" x 3 1/2". Available finished or unfinished and in most wood species. Some size restrictions apply. Contact customer service for more information.



TYPE 1



TYPE 2

PAN PULL-OUTS

Pan Pull-Outs are drawers with dividers and high-walled sides suitable for pans, cutting boards, cookie sheets, etc. Type 1 has curved sides, while Type 2 sides are angled.

SPECIALTY DRAWER BOXES



WINE DRAWER INSERTS

Wine Drawer Inserts have scoop cut-outs to accommodate wine bottles. Inserts are 3" high. Neck scoops are 2⁹/₃₂", and body scoops are 2". Custom dimensions are always welcome. Inserts are available finished or unfinished and in most wood species.

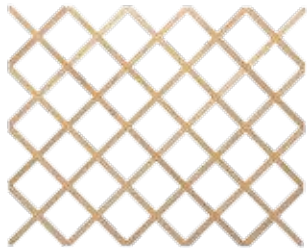

LATTICE WINE RACKS

Lattice Wine Racks are available according to your specifications. Order them in any length, any width, assembled or unassembled, finished (assembled only) in any of our finishes or unfinished, and in any wood species. Custom designs and dimensions are always welcome. Your order can also be custom color matched to your supplied color sample.



WINE BOXES

Wine Boxes may be ordered as a single or double box. The double box has a fixed center divider. The angled dividers are removable on either wine box. Specify your size requirements.



STEMWARE RACKS

Stemware Racks are available according to your specifications. Order them in any length, any width, assembled or unassembled, finished (assembled only) in any of our finishes or unfinished, and in any wood species. Custom designs and dimensions are always welcome. Your order can also be custom color matched to your supplied color sample.



CAN/SPICE PULL-OUTS

Can/Spice Pull-Outs are dovetailed and available in any wood species, finished or unfinished. Order them with one or two open sides. Shelves are adjustable. Your custom dimensions are welcome.

LASER ENGRAVING

CUSTOM LASER ENGRAVING ON WOOD

Many Keystone products are available with your logo or design element laser engraved on them.



LOGO POSITION

The default position for logos on a drawer box is inside on the right, 3" from the end and 1/2" down from the top edge. For doors, the default is for a base cabinet—centered on the back of the top rail. These default positions will be used unless otherwise indicated.

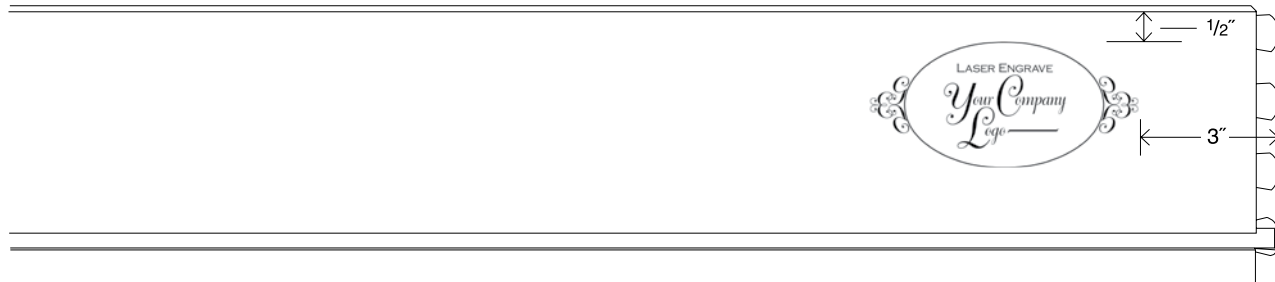

A vector EPS or high-resolution TIF or JPEG image is required.*

- Vector EPS—our first choice
- 300 DPI minimum (not usually recommended)
- 600 DPI preferred minimum
- 1200 DPI for best quality

***Your ad agency or printing company can help you with this.** A vector EPS works best. Our minimum high-resolution image file is 300 DPI, the same as that used by a commercial printing company, and is usable only if the original is oversized by 200% or more. (Most engraved logos are roughly 2.5" x 1.5", but vary depending on their shape.) Please do not send an image from your website. Website images are typically 72 DPI and are completely unusable. A setup charge may be necessary for files that require substantial work by Keystone.

When a logo file is submitted for laser engraving, we will process the file and fax or e-mail you a proof for your approval. Approval is required before we can proceed with engraving.

DRAWER SLIDES



BLUM BLUMOTION FULL-EXTENSION, SOFT-CLOSE DRAWER SLIDES

BLUMOTION 563H Series Full-Extension Drawer Slides are available in these sizes:

Blum no. 563H5330B for a 21" drawer

Blum no. 563H4570B for a 18" drawer

Blum no. 563H3810B for a 15" drawer

Blum no. 563H3050B for a 12" drawer

- Additional sizes and upgrade slides are available.
- Slides include mounting brackets, screws, and locking devices.
- Depth-Adjustable Locking Devices for Blum Undermount Slides are available upon request.
- Drawer boxes should be notched for undermount drawer slides (see page 13).
- For $\frac{3}{4}$ " thick boxes, undermount slides are available in case lots only.



BALL BEARING SIDE-MOUNT DRAWER SLIDES

Ball Bearing Side-Mount Slides are full-extension drawer slides. In addition to side-mounting drawers, these are useful for sliding cutlery trays and other sliding in-box features.

- Available sizes: 16", 18", 20", and 22"
- Heavy-duty slides are available for Waste Bin Pull-Outs.
- Additional sizes and upgrade slides are available.
- Mounting screws are included.



DOUBLE CAPTIVE EPOXY-COATED $\frac{3}{4}$ " EXTENSION DRAWER SLIDES

- Available sizes: 16", 18", 20", and 22"
- Mounting screws are included.

ROLLOUT TRAY SYSTEM

Keystone Rollout Kits have everything you need, including dovetailed drawer box trays, drawer slides, tray bumpers, and the QuikTRAY™ Rollout System.



ROLLOUT TRAY SYSTEM

QuikTRAY™ ROLLOUT SYSTEM

- Cost-efficient
- Easy to install
- Accommodates both undermount and side-mount drawer slides
- Works equally well in frame and frameless cabinets
- Installs in both new and existing cabinets
- Adjustable without tools
- “Stackable” for pantry systems
- Available in white or cream



QuikTRAY™ components are made in varied sizes to accommodate installation requirements. Call customer service for details and a measuring guide, or refer to our downloadable Price & Specification Document available on our website.

DRAWER SLIDES

Available drawer slides:

Double Captive Epoxy-Coated Drawer Slides (white or beige)

Full-Extension Ball Bearing Side-Mount Drawer Slides

Blum Undermount Drawer Slides

Blum Undermount Drawer Slides with BLUMOTION

Available drawer slide sizes: 15", 18", and 21"



DRAWER BOX TRAYS

Keystone offers drawer boxes of all sizes, in several species, and with many custom options. See page 13 for additional pull-out tray options, or visit our website for more information.

DRAWER WOOD SPECIES

The infinite variety in color, grain,* and texture is what gives wood its rich character and natural warmth. And along with all the differences among varying wood species, even within the same species, no two trees are alike. Climate, light, rainfall, and minerals in the soil all create diverse and unique grain and color patterns in each piece of wood. Because of all the variables and options available in choosing a wood species, we've prepared the following guidelines to assist you in selecting the right wood for the desired end result.

**Grain and color matching that is not acceptable to the customer is replaced at the customer's expense.*

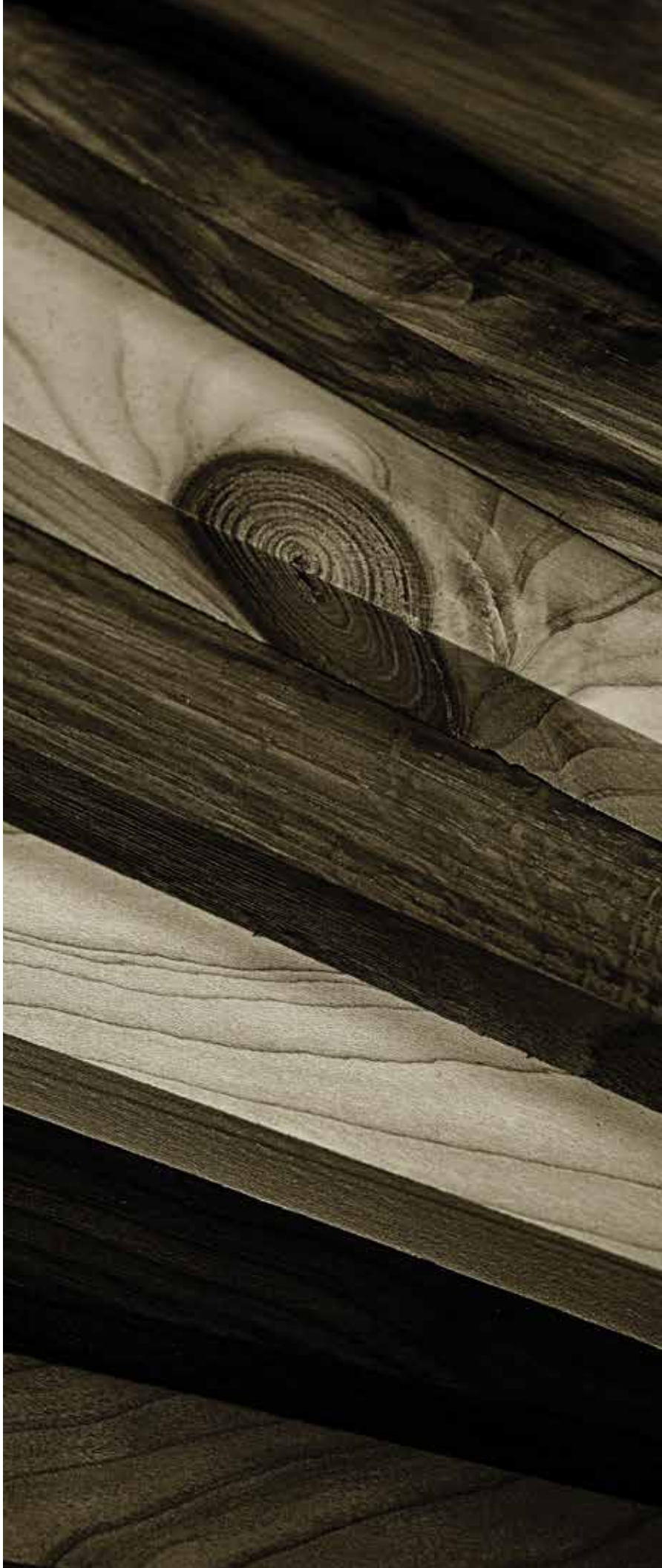

DRAWER WOOD SPECIES

ALDER

Color ranges from light tan to reddish brown, with almost no distinction between heartwood and sapwood. Alder has a fine texture with partly closed, straight grain similar to cherry. Pin knots are an acceptable characteristic.

AROMATIC CEDAR

Strong characteristics of aromatic cedar include its pleasant aroma and deep reddish-brown hue. Knots and pale yellow to white sapwood are acceptable and are present throughout. Knots vary in size and may be open, forming deep holes.

ASH

The color tones of ash consist of a wide range of cream to light brown with some dark streaks. Burl and pin knots are acceptable. Ash is not selected for color. Panel ribs are arranged to form a reasonable blend of grain matching and wood color tones.

CHERRY

Cherry may contain some white sapwood. Grain and color are matched to form a reasonable blend. Exposure to light causes cherry to darken with age, revealing a deep reddish-brown tone. Gum pockets are a natural characteristic of cherry.

MAHOGANY

Color varies: golden brown to light reddish color tones. Has occasional pin knots or burl. Natural Finish Grade mahogany is available upon request. If a specific grain pattern or color is required, contact Keystone before ordering.

MAPLE, HARD

Maple is a light brown to creamy tan wood with a subtle grain pattern and is suitable for light to dark stains. Some mineral is acceptable.

MAPLE, SOFT

Used mostly for drawers and paint grade doors, soft maple ranges from creamy white to brown to gray color tones. Color is not selected. Soft maple is not recommended for stain or natural finish.

PAULOWNIA

Heartwood ranges from a pale grayish brown to a reddish-purple hue and is not always easily distinguished from the pale white sapwood. Paulownia is a lightweight wood with a straight open grain that is stable in various environments—making it the perfect selection for boating applications.

PINE, CLEAR

A completely clear grade of pine with no knots. Blue stain is not acceptable.

PINE, KNOTTY

Our knotty pine, a New England furniture grade, has tight red knots and is suitable for rustic-style cabinetry. Filled or loose knots and blue stain are not acceptable.

POPLAR

A soft hardwood, it has a pale yellowish to white color with some green and brown mineral. Not selected for color. Typically used as a paint grade.

RED OAK

Red oak is not selected for color. Defects such as knots and splits are removed. Character, such as burl and pin knots, is acceptable. Mineral is acceptable in the range of 1/8" wide x 5" long. Panel ribs are arranged to form a reasonable blend of grain matching and color tones.

WALNUT

Walnut may have up to 15% sapwood. Burl and pin knots are acceptable.

WHITE OAK, QUARTERSAWN

Quartersawn is different than plainsawn only in the way it is cut at the sawmill. Quartersawn is cut radially to the rings or parallel to the rays and produces an edge-grained appearance and is especially suited for reproductions of furniture or cabinetry.

INDEX

DRAWER BOXES.....	10-11
ALTERNATIVE OPTIONS FOR QUANTITY & COST.....	11
DOVETAILED DRAWER BOXES.....	11
DOWELED DRAWER BOXES.....	11
OPTIONS & SIZES.....	12
ASSEMBLY PREFERENCES.....	12
DRAWER BOX SIDES.....	12
EARS FOR PULL-OUT TRAYS.....	13
GROOVE FOR SLIDING TOPS.....	13
HANDLE CUT-OUTS.....	13
MINIMUM SIZES.....	12
NOTCHING FOR UNDERMOUNT DRAWER SLIDES.....	13
SIDE PROFILES.....	13
SLOTS FOR FILE HANGERS.....	13
THICKNESS OPTIONS.....	12
WOOD SPECIES.....	12
SPECIALTY DRAWER BOXES.....	14-19
DRAWER SLIDES.....	21
BALL BEARING SIDE-MOUNT DRAWER SLIDES.....	21
BLUM BLUMOTION FULL-EXTENSION, SOFT-CLOSE DRAWER SLIDES.....	21
DOUBLE CAPTIVE EPOXY-COATED 3/4" EXTENSION DRAWER SLIDES.....	21
DRAWER WOOD SPECIES.....	24-25
FREQUENTLY ASKED QUESTIONS.....	9
LASER ENGRAVING.....	20
PLACING AN ORDER.....	8
QUIKTRAY™ ROLLOUT SYSTEM.....	23
REMAKES & ADD-ONS.....	8
ROLLOUT TRAY SYSTEM.....	22-23
SETTING UP AN ACCOUNT.....	8
SHIPPING, DELIVERY & PICKUP.....	8
SPECIALTY DRAWER BOXES.....	14-19
ADJUSTABLE DIVIDER DRAWERS.....	15
CAN/SPICE PULL-OUTS.....	19
CORNER DRAWERS.....	18
CORNER SHELVES.....	16
CUTLERY TRAYS.....	15
DOUBLE CUTLERY TRAY BOXES.....	15
FIXED/REMOVABLE DIVIDER DRAWERS.....	15
KNIFE BLOCK DRAWERS & DRAWER INSERTS.....	17
LATTICE WINE RACKS.....	19
PAN PULL-OUTS.....	18
PEG BOARD DRAWERS.....	18
SOCK & TIE DRAWERS.....	18
SPICE DRAWERS & DRAWER INSERTS.....	17
STEMWARE RACKS.....	19
U-DRAWERS.....	18
WASTE BIN PULL-OUTS.....	16
WINE BOXES.....	19
WINE DRAWER INSERTS.....	19
TRADE DISCOUNTS.....	8



CONTACT US

When you call during normal business hours, your call will be answered personally by a live staff person who will quickly direct your call.

CUSTOMER SERVICE

Phone	Toll-Free: 800.233.0289
Fax	Toll-Free: 800.253.0805
Phone	Local: 717.299.6288
Fax	Main Office: 717.299.9654
Fax	West Office: 717.295.7307
E-mail	info@keystonewood.com
Online	keystonewood.com

MAILING ADDRESS

Keystone Wood Specialties Inc.
PO Box 10127
Lancaster, PA 17605-0127

PHYSICAL SHIPPING ADDRESS

Keystone Wood Specialties Inc.
2225 Old Philadelphia Pike
Lancaster, PA 17602

NORMAL OFFICE HOURS

Monday–Friday, 8 am–5 pm EST
Fax lines are open 24 hours, 7 days a week.



QUALITY CRAFTSMANSHIP YOU CAN DEPEND ON



717.299.6288
kestonewood.com
P.O. Box 10127 Lancaster, PA 17605

July 2016